

The Maker Of A **PERFECT BALL & STEM VALVE** On The Engine Lathe
 The Holdridge Spherical Tool has been designed and built to machine a precise spherical ball with minimum set-up.
 The Holdridge Stem Valve Tool has been designed and built to machine a precise stem valve with minimum set-up.

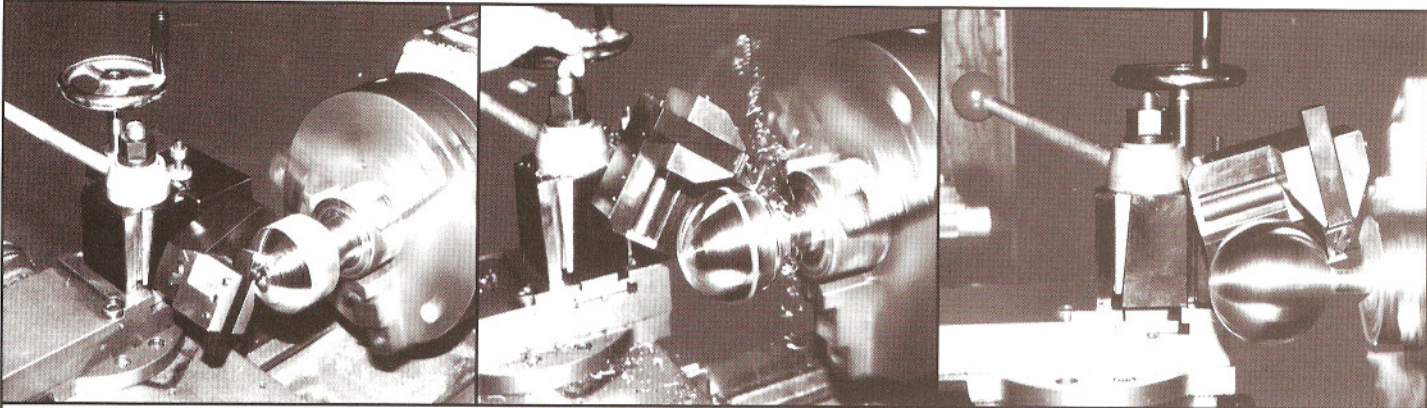

Quick to set-up

Powerful for heavy cuts

Gentle for a precise and smooth finish

Super precise

Precise and true within .0001 tolerance, the Holdridge spherical tool makes a perfect spherical ball, or spherical cavity, with a mirror finish.

- Tolerance Below .0001 Roundness
- Micro Finish Below 16µin.

Diameter capacity

The 4" ,6" ,8" , and 12" tools are stocked. Larger sizes are available upon request.

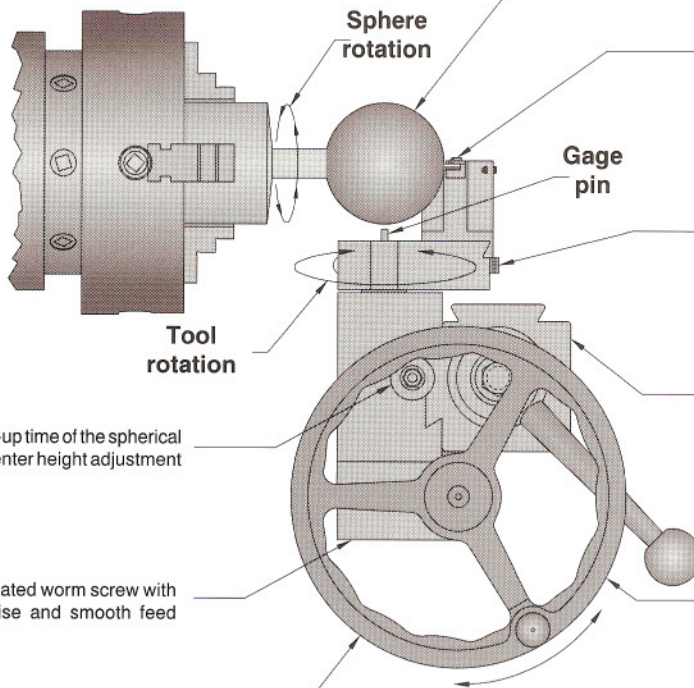

Cutting tool

TCMT inserts are used for O.D. operations while solid carbide or brazed tools are used for I.D. operations.

Diameter micro adjustment

A dial micro screw gives direct readings of the cut depth and the diameter of the sphere. It is adjustable while the tool is in operation.

Quick change mounting

To maximize the flexibility of the tool for the wide range of engine lathes, the Holdridge spherical tool has been designed to fit the industry standard tool post.

Easy set-up

To simplify and minimize the set-up time of the spherical tool, a quick tool setting and a center height adjustment is provided.

Gear box

Bronze worm gear and heat-treated worm screw with a Timken bearing, for a precise and smooth feed control.

Feed control

For best surface and feed control, the spherical tool uses a worm gear speed reducer. The worm screw, mounted between thrust and ball bearings, makes the forming of the sphere precise and uniform. The high ratios, 16:1 up to 40:1, reduce the tool drag, making the hand wheel control easy to operate.

High Performance

The Holdridge spherical tool can be power driven with a motor drive in place of the hand wheel or hand operated for direct drive when soft material is used.

Heavy duty

The Holdridge spherical tool is crafted with precise workmanship and quality, using selected materials and components to maximize rigidity and withstand the everyday rigors a fine tool must endure.

Spherical Operation

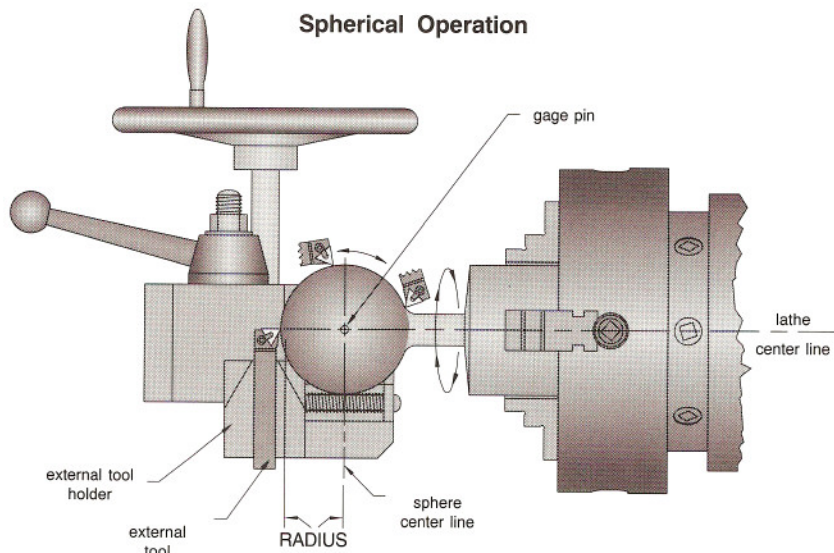

How to set-up for a spherical operation:

Use the gage pin as a reference point to set-up the cutting tool, the diameter of the sphere, and the lathe center height.

1. Set the cutting tool in the center line with the gage pin.
2. Set the desired radius by measuring the distance between the gage pin and the cutting tool .
3. Place the spherical tool on the tool post, using the gage pin to check for the lathe center height.
4. Position the gage pin in the center of the sphere.
5. Feed the tool to the working part counterclockwise.
6. If the vertical dimension of the sphere is larger than the horizontal dimension, the spherical tool is above the lathe center height. The tool must be dropped one-half the difference between the two dimensions.

Concave Operation

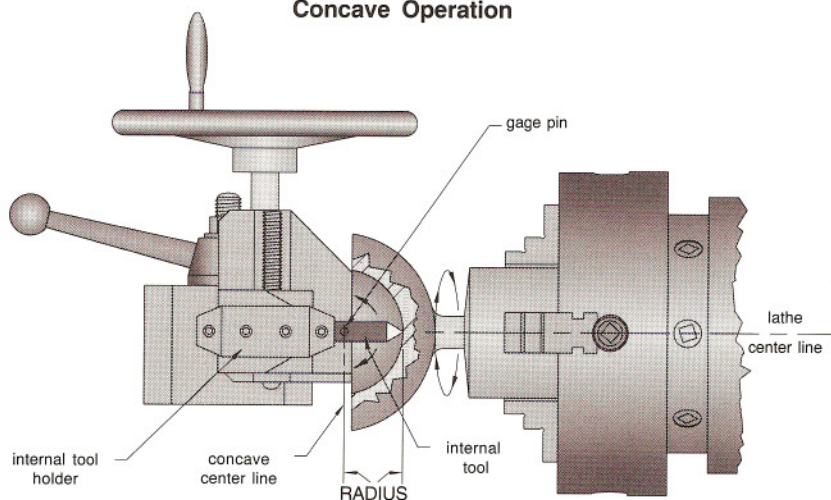

How to set-up for a concave operation:

Use the gage pin as a reference point to set-up the cutting tool, the diameter of the concave, and the lathe center height.

1. Place the internal tool holder in the spherical tool.
2. Using the gage pin as a reference, set the internal tool holder in the center line of the spherical tool, and then lock the tool holder.
3. Place the spherical tool on the tool post, using the gage pin to check for lathe center height.
4. Set the desired diameter by measuring the distance between the gage pin and the cutting tool.
5. Feed the tool to the working part counterclockwise.
6. If the vertical dimension of the concave is larger than the horizontal dimension, the spherical tool is above the lathe center height. The tool must be dropped one-half the difference between the two dimensions.

For full diameter in concave operations, the tool holder is to be designed according to the diameter to be machined and quoted accordingly. Please submit a drawing of the part.

Spherical Tool		Spherical Tool Specifications				External Tools				Internal Tool Holder					* Allen Wrench				
		Center height		Tool Post	Gear Box Ratio	Max. Dia. Capacity	Extension Tool Holder		* External Toolholder Part No.	* Insert Size	* Part No.	Tool Dia. Capacity		Bushing Tool No.		Bushing I.D.	Internal Tool No.	Internal Tool Dia.	
Part No.	Price	in	mm				Part No.	Price				in	mm						
DST20-25	\$1,080.00	1-1/8	28,6	SD25AXA	1:20	2.0	4.0	ESTH-20	\$185.00	MTFNL8-2	TCMT-21	ISTH20-2531	1/4 & 5/16	6 & 8	THB-3112	1/8	SRE-44	1/8	3/32
DST20-30	\$1,080.00	1-1/8	28,6	SD30BXA											SRE-66	3/16	5/32		
															THB-3118	3/16	SRE-88	1/4	1/4
																	TRE-50*	5/16	5/16
DST30-35	\$1,440.00	1-3/8	34,9	SD35CX A	1:24	3.0	6.0	ESTH-30	\$240.00	MTFNL10-2	TCMT-21	ISTH30-3850	3/8 & 1/2	10 & 12	THB-5025	1/4	SRE-88	1/4	1/8
															TRE-5	5/16	3/32		
															THB-5031	5/16	TRE-6	3/8	1/4
																	TRE-80*	1/2	1/4
DST40-40	\$1,690.00	1-3/4	44,5	SD40CA	1:30	4.0	8.0	ESTH-40	\$320.00	MTFNL12-3	TCMT-32	ISTH40-3850	3/8 & 1/2	10 & 12	THB-5025	1/4	SRE-88	1/4	1/8
															TRE-5	5/16	3/16		
															THB-5031	5/16	TRE-6	3/8	5/16
																	TRE-80*	1/2	1/4
DST60-50	\$2,360.00	2.0	50,8	SD50DA	1:40	6.0	12.0	ESTH-60	\$460.00	MTFNL16-3	TCMT-32	ISTH60-3850	3/8 & 1/2	10 & 12	THB-5025	1/4	SRE-88	1/4	1/8
															TRE-5	5/16	1/4		
DST60-60	\$2,580.00	2.0	50,8	SD60EA											THB-5031	5/16	TRE-6	3/8	1/4
																	TRE-80*	1/2	3/8

* Supplied with Spherical Tool

** Maximum diameter when extension tool holder is used
EXTENTION TOOL HOLDER IS SOLD SEPERATELY