

TUNGALOY PROMOTIONS



**OFFERS VALID UNTIL
DECEMBER 31ST, 2013**

DOMINIBORE

Sharpness of positive inserts with twice the number of cutting edges

BUY 20 INSERTS
GET FREE
BORING BAR!



SWLXR/L Boring & internal facing

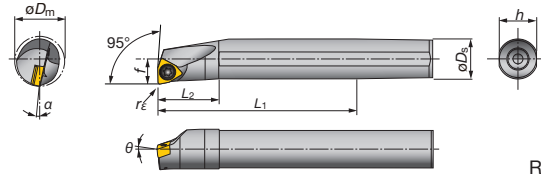
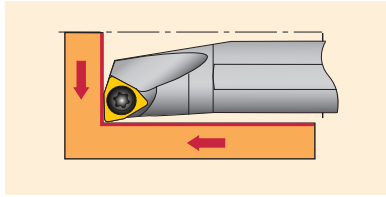

Right hand (R) shown

SDXXR/L Boring & internal profiling

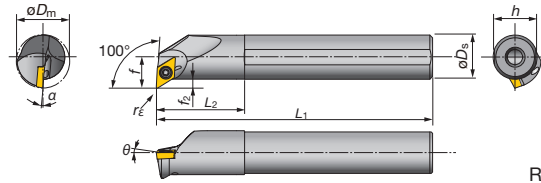
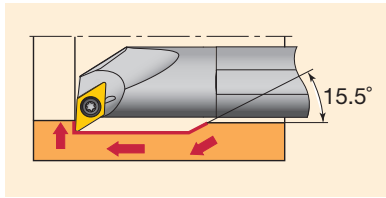

Right hand (R) shown

Boring Bar

| Cat. No | Stock | | Min bore dia. ϕD_m | Dimensions (in) | | | | | | | | Std. corner radius r_f | Insert | Parts | | Torque (N•m) | 1 Boring Bar & 20 inserts |
|--------------------|-------|---|--------------------------|-----------------|------|-------|-------|------|-------|----------|------|--------------------------|----------------|----------------|--------|--------------|---------------------------|
| | R | L | | ϕD_s | f | L_1 | L_2 | h | f_2 | θ | a | | | Clamping Screw | Wrench | | |
| A06-SWLXR/L2 - D08 | ● | ● | .500 | .375 | .281 | 5.000 | .750 | .350 | - | -10° | -14° | .016 | WXGU04* L/R | SR34-514 | T-7F | 0.9 | \$220.67 |
| A08-SWLXR/L2 - D11 | ● | ● | .688 | .500 | .406 | 5.000 | 1.00 | .475 | - | -10° | -10° | .016 | | | | | \$220.67 |
| A10-SWLXR/L2 - D14 | ● | ● | .875 | .625 | .531 | 7.000 | 1.25 | .600 | - | -10° | -8° | .016 | | | | | \$220.67 |
| A12-SWLXR/L2 - D16 | ● | ● | 1.000 | .750 | .593 | 7.000 | 1.438 | .725 | - | -10° | -7° | .016 | | | | | \$220.67 |
| A06-SDXXR/L2 - D10 | ● | ● | .625 | .375 | .406 | 5.000 | .750 | .350 | - | -14° | -12° | .016 | DXGU07* L/R | SR34-514 | T-7F | 0.9 | \$250.00 |
| A08-SDXXR/L2 - D11 | ● | ● | .688 | .500 | .406 | 5.000 | 1.00 | .475 | - | -13.5° | -11° | .016 | | | | | \$250.00 |
| A10-SDXXR/L2 - D14 | ● | ● | .875 | .625 | .531 | 7.000 | 1.25 | .600 | - | -13° | -9° | .016 | | | | | \$250.00 |
| A12-SDXXR/L2 - D16 | ● | ● | 1.000 | .750 | .593 | 7.000 | 1.438 | .725 | - | -13° | -8° | .016 | | | | | \$250.00 |

Note: When using a right or left hand insert, the right hand insert (R) is used for the left hand toolholders and the left hand insert (L) is used for the right hand toolholders.

Inserts

| Chipbreaker | | Cat. No | Grades | | | Dimensions (in) | | | |
|------------------------|------------------|--------------|--------|---------------|--------|--------------------|---------------|----------------------|---------------------|
| TS for General Purpose | SS for Stainless | | Coated | Coated Cermet | Cermet | I.C. dia. ϕd | Thickness s | Hole dia. ϕd_1 | Corner Radius r_f |
| | | | AH725 | GT530 | NS530 | | | | |
| | | WXGU040302L* | ◆ | ● | ● | .250 | .125 | .106 | .008 |
| | | WXGU040302R* | ● | ● | ● | | | | .016 |
| | | WXGU040304L* | ●◆ | ●◆ | ●◆ | | | | .031 |
| | | WXGU040304R* | ●◆ | ●◆ | ● | | | | |
| | | WXGU040308L* | ◆ | ◆ | ◆ | | | | |
| | | WXGU040308R* | ◆ | ◆ | ◆ | | | | |
| | | DXGU070302L* | ● | ● | ● | .250 | .125 | .106 | .008 |
| | | DXGU070302R* | ● | ● | ● | | | | .016 |
| | | DXGU070304L* | ●◆ | ●◆ | ●◆ | | | | .031 |
| | | DXGU070304R* | ● | ● | ●◆ | | | | |
| | | DXGU070308L* | ◆ | ◆ | ◆ | | | | |
| | | DXGU070308R* | ◆ | | | | | | |

Promo code: TG027 • Offers valid until December 31st, 2013

Chipbreaker Options: SS = ● TS = ◆



**BUY 30 INSERTS
GET 10 FREE!**

NEW

Cermet grade for steel turning

- Improved toughness with exceptional fracture and wear resistance.

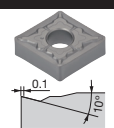
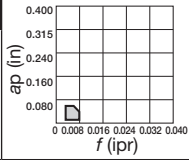
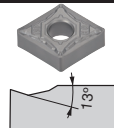
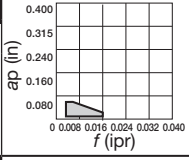
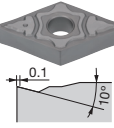
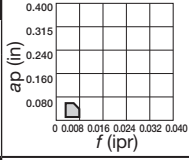
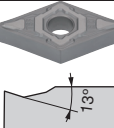
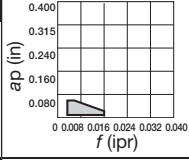
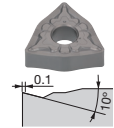
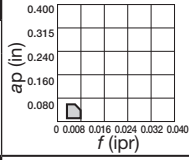
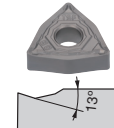
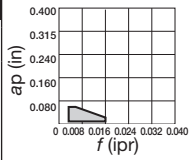
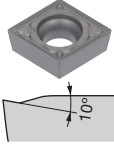
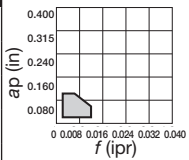
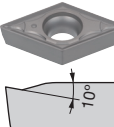
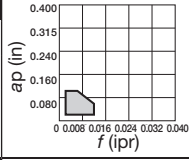
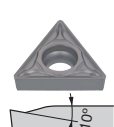
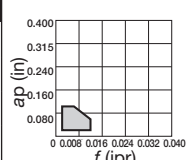
NS9530 GT9530

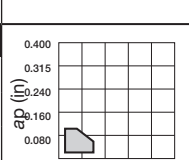
| Application | Chipbreaker Appearance (Cross Section) | f - ap | Cat. No. | Stocked Grades | | Dimensions (in) | | | |
|--|---|---|---------------|----------------|---------------|-----------------|----------------|-----------------------------|---------------------------------|
| | | | | Cermet | Coated Cermet | I.C. dia ød | Thickness s | Hole dia ød ₁ | Corner radius r _ε |
| | | | | NS9530 | GT9530 | | | | |
| Finishing | TS  |  | CNMG 431 TS | ● | ● | .500 | .187 | .203 | .016 |
| | | | CNMG 432 TS | ● | ● | | | | .031 |
| | TSF  |  | CNMG 431 TSF | ● | ● | .500 | .187 | .203 | .016 |
| | | | CNMG 432 TSF | ● | ● | | | | .031 |
| | TS  |  | DNMG 431 TS | ● | ● | .500 | .187 | .203 | .016 |
| | | | DNMG 432 TS | ● | ● | | | | .031 |
| | TSF  |  | DNMG 431 TSF | ● | ● | .500 | .187 | .203 | .016 |
| | | | DNMG 432 TSF | ● | ● | | | | .031 |
| | TS  |  | WNMG 431 TS | ● | ● | .500 | .187 | .203 | .016 |
| | | | WNMG 432 TS | ● | ● | | | | .031 |
| | TSF  |  | WNMG 431 TSF | ● | ● | .500 | .187 | .203 | .016 |
| | | | WNMG 432 TSF | ● | ● | | | | .031 |
| Finishing to medium cutting | PS  |  | CCMT060202-PS | ● | ● | .250 | .094 | .110 | .008 |
| | | | CCMT060204-PS | ● | ● | | | | .016 |
| | | | CCMT060208-PS | ● | ● | | | | .031 |
| | | | CCMT09T302-PS | ● | ● | .375 | .156 | .173 | .008 |
| | | | CCMT09T304-PS | ● | ● | | | | .016 |
| | | | CCMT09T308-PS | ● | ● | | | | .031 |
| | PS  |  | DCMT11T302-PS | ● | ● | .375 | .156 | .173 | .008 |
| | | | DCMT11T304-PS | ● | ● | | | | .016 |
| | | | DCMT11T308-PS | ● | ● | | | | .031 |
| | PS  |  | TCMT110202-PS | ● | ● | .250 | .094 | .110 | .008 |
| | | | TCMT110204-PS | ● | ● | | | | .016 |
| | | | TCMT110208-PS | ● | ● | | | | .031 |
| TCMT16T304-PS | | | ● | ● | .016 | | | | |
| PS  |  | TPMT110202-PS | ● | ● | .250 | .094 | .110 | .008 | |
| | | TPMT110204-PS | ● | ● | | | | .016 | |
| | | TPMT110208-PS | ● | ● | | | | .031 | |

• No mix and match.

3 Promo code: TG030 • Offers valid until December 31st, 2013

DOFEED

New-generation of high feed cutters offering incredible productivity

BUY 20 INSERTS & RECEIVE 25% OFF CUTTER!

BUY 30 INSERTS & RECEIVE 50% OFF CUTTER!

• Shellmill

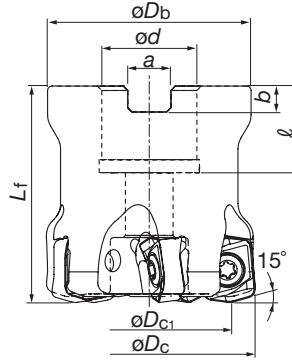

LNMU03 type: Max. ap = .039"
LNMU06 type: Max. ap = .059"

• Shank

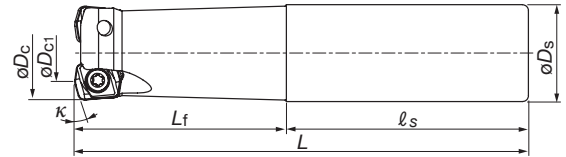

Shellmill

| Cat. No. | Stock | No. of Inserts | Dimensions (in) | | | | | | | | Weight (lb) | Airhole | Insert | 1 Shellmill & 20 inserts | 1 Shellmill & 30 inserts |
|-------------------|-------|----------------|-----------------|----------------|------------|----------|--------|-------|------|------|-------------|---------|-------------|--------------------------|--------------------------|
| | | | ϕD_c | ϕD_{c_1} | ϕD_b | ϕd | ℓ | L_f | b | a | | | | | |
| TXN06R200U0075A04 | ● | 4 | 2.000 | 1.513 | 1.850 | .750 | .750 | 1.969 | .197 | .315 | 1.1 | with | LNMU06X5ZER | \$718.60 | \$810.94 |
| TXN06R200U0075A05 | ● | 5 | 2.000 | 1.513 | 1.850 | .750 | .750 | 2.000 | 1.97 | .315 | .88 | | | \$753.82 | \$834.41 |
| TXN06R250U0075A04 | ● | 4 | 2.500 | 2.012 | 2.323 | .750 | .750 | 1.969 | .197 | .315 | 1.5 | | | \$747.89 | \$830.46 |
| TXN06R250U0075A06 | ● | 6 | 2.500 | 2.012 | 2.323 | .750 | .750 | 1.969 | .197 | .315 | 1.5 | | | \$821.32 | \$879.41 |
| TXN06R300U0100A05 | ● | 5 | 3.000 | 2.512 | 2.835 | 1.000 | 1.024 | 2.480 | .236 | .374 | 3.3 | | | \$801.44 | \$866.16 |
| TXN06R300U0100A07 | ● | 7 | 3.000 | 2.512 | 2.835 | 1.000 | 1.024 | 2.500 | .236 | .374 | 3.3 | | | \$886.12 | \$922.61 |

BUY 50 INSERTS GET FREE CUTTER!

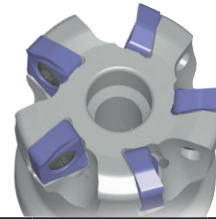

Shellmill

| Cat. No. | Stock | No. of Inserts | Dimensions (in) | | | | | | | | Weight (lb) | Airhole | Insert | 1 Shellmill & 50 inserts |
|-------------------|-------|----------------|-----------------|----------------|------------|----------|--------|-------|------|------|-------------|-------------|-------------|--------------------------|
| | | | ϕD_c | ϕD_{c_1} | ϕD_b | ϕd | ℓ | L_f | b | a | | | | |
| TXN06R200U0075A04 | ● | 4 | 2.000 | 1.513 | 1.850 | .750 | .750 | 1.969 | .197 | .315 | 1.1 | with | LNMU06X5ZER | \$995.60 |
| TXN06R200U0075A05 | ● | 5 | 2.000 | 1.513 | 1.850 | .750 | .750 | 2.000 | 1.97 | .315 | .88 | | | \$995.60 |
| TXN06R250U0075A04 | ● | 4 | 2.500 | 2.012 | 2.323 | .750 | .750 | 1.969 | .197 | .315 | 1.5 | | | \$995.60 |
| TXN06R250U0075A06 | ● | 6 | 2.500 | 2.012 | 2.323 | .750 | .750 | 1.969 | .197 | .315 | 1.5 | | | \$995.60 |
| TXN06R300U0100A05 | ● | 5 | 3.000 | 2.512 | 2.835 | 1.000 | 1.024 | 2.480 | .236 | .374 | 3.3 | | | \$995.60 |
| TXN06R300U0100A07 | ● | 7 | 3.000 | 2.512 | 2.835 | 1.000 | 1.024 | 2.500 | .236 | .374 | 3.3 | | | \$995.60 |
| TXN03R150U0075A06 | ● | 6 | 1.500 | 1.248 | 1.461 | .750 | .750 | 1.969 | .197 | .315 | .44 | | | \$585.20 |
| TXN03R200U0075A08 | ● | 8 | 2.000 | 1.748 | 1.693 | .750 | .750 | 1.969 | .197 | .315 | 1.1 | LNMU0303ZER | \$585.20 | |
| TXN03R200U0075A10 | ● | 10 | 2.000 | 1.748 | 1.693 | .750 | .750 | 1.969 | .197 | .315 | 1.1 | | \$585.20 | |

BUY 10 INSERTS RECEIVE 50% OFF CUTTER!

BUY 20 INSERTS RECEIVE 70% OFF CUTTER!

BUY 30 INSERTS GET FREE CUTTER!

Shank

| Cat. No. | Stock | No. of Inserts | Dimensions (in) | | | | | | | Weight (lb) | Airhole | Insert | 1 Shank & 10 inserts | 1 Shank & 20 inserts | 1 Shank & 30 inserts |
|--------------------|-------|----------------|-----------------|------------|----------------|--------|-------|----------|------|-------------|----------------|----------|----------------------|----------------------|----------------------|
| | | | ϕD_c | ϕD_s | ϕD_{c_1} | L | L_f | ℓ_s | | | | | | | |
| EXN06R125U0125W02 | ● | 2 | 1.250 | 1.250 | .766 | 5.000 | 3.000 | 2.000 | 1.76 | with | LNMU06X5ZER-M* | \$343.85 | \$485.08 | \$597.36 | |
| EXN06R150U0125W03 | ● | 3 | 1.500 | 1.250 | 1.014 | 6.000 | 3.500 | 2.500 | 1.98 | | | \$372.77 | \$502.43 | \$597.36 | |
| EXN06R125U0125-02L | ● | 2 | 1.250 | 1.250 | .766 | 8.000 | 5.000 | 3.000 | 2.43 | | | \$358.32 | \$493.76 | \$597.36 | |
| EXN06R150U0125-03L | ● | 3 | 1.500 | 1.250 | 1.014 | 10.000 | 2.000 | 8.000 | 2.87 | | | \$390.15 | \$512.86 | \$597.36 | |

Promo code: TG025 • Offers valid until December 31st, 2013

**BUY 10 INSERTS
RECEIVE 50% OFF
CUTTER!**

**BUY 20 INSERTS
RECEIVE 70% OFF
CUTTER!**

Shank

| Cat. No. | Stock | No. of Inserts | Dimensions (in) | | | | | | Weight (lb) | Airhole | Insert | 1 Shank & 10 inserts | 1 Shank & 20 inserts |
|--------------------|-------|----------------|-----------------|------|------------------|-------|----------------|----------------|-------------|---------|----------------|----------------------|----------------------|
| | | | øDc | øDs | øDc ₁ | L | L _f | ℓ _s | | | | | |
| EXN03R062U0062-02 | ● | 2 | .625 | .625 | .374 | 4.000 | 1.250 | 2.750 | .44 | with | LNMU0303ZER-M* | \$226.29 | \$299.63 |
| EXN03R068U0062-02 | ● | 2 | .688 | .625 | .433 | 4.000 | 1.250 | 2.750 | .44 | | | \$226.29 | \$299.63 |
| EXN03R075U0075-03 | ● | 3 | .750 | .750 | .496 | 5.000 | 2.000 | 3.000 | .66 | | | \$262.69 | \$321.47 |
| EXN03R087U0075-03 | ● | 3 | .875 | .750 | .496 | 5.000 | 2.000 | 3.000 | .66 | | | \$262.69 | \$321.47 |
| EXN03R062U0062-02L | ● | 2 | .625 | .625 | .374 | 6.000 | 2.000 | 4.000 | .44 | | | \$242.64 | \$309.44 |
| EXN03R068U0062-02L | ● | 2 | .688 | .625 | .433 | 6.000 | 1.000 | 5.000 | .44 | | | \$242.64 | \$309.44 |
| EXN03R075U0075-03L | ● | 3 | .750 | .750 | .496 | 6.500 | 3.500 | 3.000 | .66 | | | \$284.49 | \$334.55 |
| EXN03R087U0075-03L | ● | 3 | .875 | .750 | .634 | 6.500 | 1.250 | 5.250 | .88 | | | \$284.49 | \$334.55 |

**BUY 30 INSERTS
GET FREE
CUTTER!**



Shank

| Cat. No. | Stock | No. of Inserts | Dimensions (in) | | | | | | Weight (lb) | Airhole | Insert | 1 Shank & 30 inserts |
|--------------------|-------|----------------|-----------------|-------|------------------|-------|----------------|----------------|-------------|---------|----------------|----------------------|
| | | | øDc | øDs | øDc ₁ | L | L _f | ℓ _s | | | | |
| EXN03R062U0062-02 | ● | 2 | .625 | .625 | .374 | 4.000 | 1.250 | 2.750 | .44 | with | LNMU0303ZER-M* | \$351.12 |
| EXN03R068U0062-02 | ● | 2 | .688 | .625 | .433 | 4.000 | 1.250 | 2.750 | .44 | | | \$351.12 |
| EXN03R075U0075-03 | ● | 3 | .750 | .750 | .496 | 5.000 | 2.000 | 3.000 | .66 | | | \$351.12 |
| EXN03R087U0075-03 | ● | 3 | .875 | .750 | .634 | 5.000 | 2.000 | 3.000 | .66 | | | \$351.12 |
| EXN03R100U0100-05 | ● | 5 | 1.000 | 1.000 | .756 | 5.500 | 2.500 | 3.000 | 1.10 | | | \$351.12 |
| EXN03R112U0100-05 | ● | 5 | 1.125 | 1.000 | .882 | 5.500 | 2.500 | 3.000 | 1.10 | | | \$351.12 |
| EXN03R125U0125-06 | ● | 6 | 1.250 | 1.250 | 1.008 | 6.000 | 3.000 | 3.000 | 2.43 | | | \$351.12 |
| EXN03R062U0062-02L | ● | 2 | .625 | .625 | .374 | 6.000 | 2.000 | 4.000 | .44 | | | \$351.12 |
| EXN03R068U0062-02L | ● | 2 | .688 | .625 | .433 | 6.000 | 1.000 | 5.000 | .44 | | | \$351.12 |
| EXN03R075U0075-03L | ● | 3 | .750 | .750 | .496 | 6.500 | 3.500 | 3.000 | .66 | | | \$351.12 |
| EXN03R087U0075-03L | ● | 3 | .875 | .750 | .634 | 6.500 | 1.250 | 5.250 | .88 | | | \$351.12 |
| EXN03R100U0100-04L | ● | 4 | 1.000 | 1.000 | .756 | 7.000 | 4.000 | 3.000 | 1.32 | | | \$351.12 |
| EXN03R112U0100-04L | ● | 4 | 1.125 | 1.000 | .882 | 7.000 | 1.500 | 5.500 | 1.54 | | | \$351.12 |
| EXN03R125U0125-05L | ● | 5 | 1.250 | 1.250 | 1.008 | 8.000 | 5.000 | 3.000 | 2.43 | | | \$351.12 |

Inserts

LNMU03 type

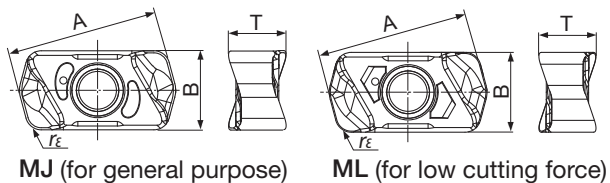

NEW! LNMU06 type

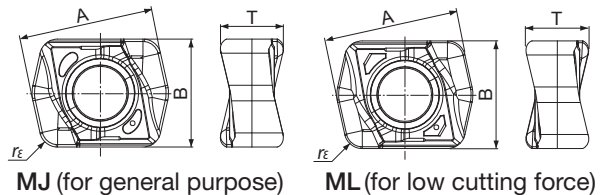

| Cat. No. | Accuracy | Honing | Grades | | | | Dimensions (in) | | | |
|----------------|----------|--------|--------|-------|-------|--------|-----------------|------|------|----------------|
| | | | AH725 | AH120 | AH130 | AH3035 | A | B | T | r _ε |
| LNMU0303ZER-MJ | M | with | ● | | ● | ● | .456 | .236 | .169 | .047 |
| LNMU0303ZER-ML | M | with | ● | | ● | ● | | | | |
| LNMU06X5ZER-MJ | M | with | ● | ● | ● | ● | .591 | .472 | .276 | .079 |
| LNMU06X5ZER-ML | M | with | ● | ● | ● | ● | | | | |

Replacement parts

| Description | | Parts Cat. No. |
|----------------|--------|----------------|
| Clamping Screw | | CSPB-5 |
| Wrench | Bit | BLD IP20/S7 |
| | Handle | H-TBS |

Promo code: TG025 • Offers valid until December 31st, 2013

DOFEED QUAD

Remarkable productivity with tough cutting edges

**BUY 50 INSERTS
GET FREE
CUTTER!**

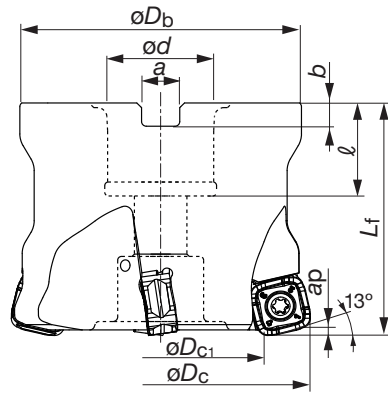

Max. ap = .079"

Cutter

| Cat. No. | Stock | No. of inserts | Dimensions (in) | | | | | | | | Weight (lb) | Airhole | Center bolt | Insert | 1 Cutter & 50 inserts |
|-------------------|-------|----------------|-------------------|-----------------------|-------------------|-----------------|--------|-------|------|------|-------------|---------|-----------------|--------------------|-----------------------|
| | | | $\varnothing D_c$ | $\varnothing D_{c_1}$ | $\varnothing D_b$ | $\varnothing d$ | ℓ | L_f | b | a | | | | | |
| TXQ12R200U0075A03 | ● | 3 | 2.000 | 1.362 | 1.850 | .750 | .750 | 1.969 | .197 | .315 | 1.12 | with | (C0.375X1.125H) | SQMU1206 ZSR-MJ | \$1,010.80 |
| TXQ12R200U0075A04 | ● | 4 | 2.000 | 1.362 | 1.850 | .750 | .750 | 1.969 | .197 | .315 | 1.12 | | (C0.375X1.125H) | | \$1,010.80 |
| TXQ12R250U0075A04 | ● | 4 | 2.500 | 1.862 | 2.323 | .750 | .750 | 1.969 | .197 | .315 | 1.76 | | (C0.375X1.125H) | | \$1,010.80 |
| TXQ12R300U0100A05 | ● | 5 | 3.000 | 2.362 | 2.835 | 1.000 | 1.024 | 2.480 | .236 | .374 | 3.77 | | (C0.500X1.375H) | | \$1,010.80 |
| TXQ12R400U0150A06 | ● | 6 | 4.000 | 3.362 | 3.780 | 1.500 | 1.457 | 2.480 | .394 | .626 | 5.71 | | (TMBA-0.750H) | | \$1,010.80 |
| TXQ12R500U0150A07 | ● | 7 | 5.000 | 4.362 | 3.780 | 1.500 | 1.457 | 2.480 | .394 | .626 | 7.01 | | (TMBA-0.750H) | | \$1,010.80 |
| TXQ12R600U0200A08 | ● | 8 | 6.000 | 5.370 | 3.937 | 2.000 | 1.496 | 2.480 | .433 | .748 | 9.70 | | - | | \$1,010.80 |

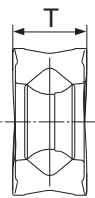
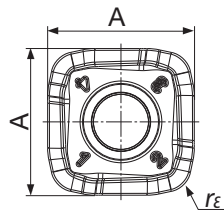

Front



Back

Inserts

| Cat. No. | Accuracy | Honing | Grades PREMIUMTEC | | | | Dimensions (in) | | |
|----------------|----------|--------|-----------------------------|-------|-------|-------|-----------------|------|--------------|
| | | | AH725 | AH130 | AH120 | T3130 | A | T | r_ϵ |
| SQMU1206ZSR-MJ | M | with | ● | ● | ● | ● | .461 | .236 | .079 |

Grade Selection

| Grades | P Steel | M Stainless | K Cast Iron | S Super alloys | H Hard Materials |
|--------|----------------------------|-----------------------|-----------------------|--------------------------|----------------------------|
| AH725 | ◎ | | ○ | ◎ | ◎ |
| AH130 | ○ For impact resistance | ◎ | | | |
| AH120 | | | ◎ | | |
| T3130 | ○ For wear resistance | | | | |

◎ : First choice
○ : Applicable

Replacement parts

| Description | Parts Cat. No. | |
|----------------|----------------|-------------|
| Clamping Screw | CSPB-4 | |
| Wrench | Bit | BLD IP15/S7 |
| | Handle | H-TBS |

Promo code: GUS03 • Offers valid until December 31st, 2013

BUY 1 DRILL &
20 INSERTS. RECEIVE 50%
OFF DRILL BODY!

TUNGSIX-DRILL

The most economical solution for drilling

Drills

| Cat. No. | Stock | Dimensions (in) | | | | | | Max Offset (Radius) | Weight (lb) | Applicable inserts | Clamping Screw | Torx driver | 1 Drill & 20 inserts |
|-------------|-------|-----------------|-------|-------|-------|-------|--------|---------------------|-------------|--------------------|----------------|-------------|----------------------|
| | | øDc | øDs | øD | ℓ | ℓs | L | | | | | | |
| TDSU1125-02 | ● | 1.125 | 1.250 | 1.575 | 2.250 | 2.280 | 5.892 | .043 | 1.5 | WWWU08X408R* | CSTB-3 | T-9D | \$472.49 |
| TDSU1187-02 | ● | 1.187 | | | 2.374 | | 6.079 | .019 | 1.6 | | | | \$472.49 |
| TDSU1250-02 | ● | 1.250 | | | 2.500 | | 6.267 | .008 | 1.7 | | | | \$498.59 |
| TDSU1312-02 | ● | 1.312 | 1.500 | 1.969 | 2.624 | 2.688 | 6.862 | .055 | 2.5 | WWWU09X510R* | CSTB-4 | T-15D | \$498.59 |
| TDSU1375-02 | ● | 1.375 | | | 2.750 | | 7.049 | .047 | 2.6 | | | | \$515.09 |
| TDSU1437-02 | ● | 1.437 | | | 2.874 | | 7.237 | .027 | 2.8 | | | | \$526.09 |
| TDSU1500-02 | ● | 1.500 | | | 3.000 | | 7.424 | .015 | 2.9 | | | | \$526.09 |
| TDSU1562-02 | ● | 1.562 | | | 3.124 | | 7.612 | .074 | 3.0 | | | | \$526.09 |
| TDSU1625-02 | ● | 1.625 | | | 3.250 | | 7.799 | .059 | 3.3 | | | | \$543.27 |
| TDSU1687-02 | ● | 1.687 | | | 3.374 | | 7.987 | .051 | 3.5 | | | | \$543.27 |
| TDSU1750-02 | ● | 1.750 | 2.165 | 3.500 | 8.174 | 2.688 | 8.174 | .027 | 3.7 | WWWU11X512R* | CSTB-5 | T-20D | \$565.29 |
| TDSU1812-02 | ● | 1.812 | | | 3.624 | | 8.362 | .015 | 3.9 | | | | \$565.29 |
| TDSU1875-02 | ● | 1.875 | | | 3.750 | | 8.549 | .094 | 4.2 | | | | \$658.63 |
| TDSU1937-02 | ● | 1.937 | | | 3.874 | | 8.737 | .078 | 4.3 | | | | \$658.63 |
| TDSU2000-02 | ● | 2.000 | | | 4.000 | | 8.924 | .067 | 4.6 | | | | \$658.63 |
| TDSU1125-03 | ● | 1.125 | 1.250 | 1.575 | 3.375 | 2.280 | 7.017 | .043 | 1.7 | WWWU08X408R* | CSTB-3 | T-9D | \$485.54 |
| TDSU1187-03 | ● | 1.187 | | | 3.561 | | 7.267 | .019 | 1.8 | | | | \$485.54 |
| TDSU1250-03 | ● | 1.250 | | | 3.750 | | 7.517 | .008 | 1.9 | | | | \$513.02 |
| TDSU1312-03 | ● | 1.312 | 1.500 | 1.969 | 3.936 | 2.688 | 8.174 | .055 | 2.8 | WWWU09X510R* | CSTB-4 | T-15D | \$513.02 |
| TDSU1375-03 | ● | 1.375 | | | 4.125 | | 8.424 | .047 | 2.9 | | | | \$530.19 |
| TDSU1437-03 | ● | 1.437 | | | 4.311 | | 8.674 | .027 | 3.1 | | | | \$541.22 |
| TDSU1500-03 | ● | 1.500 | | | 4.500 | | 8.924 | .015 | 3.3 | | | | \$541.22 |
| TDSU1562-03 | ● | 1.562 | | | 4.686 | | 9.174 | .074 | 3.4 | | | | \$541.22 |
| TDSU1625-03 | ● | 1.625 | | | 4.875 | | 9.424 | .059 | 3.8 | | | | \$547.32 |
| TDSU1687-03 | ● | 1.687 | | | 5.061 | | 9.674 | .051 | 4.1 | | | | \$547.32 |
| TDSU1750-03 | ● | 1.750 | 2.165 | 5.250 | 9.924 | 2.688 | 9.924 | .027 | 4.3 | WWWU11X512R* | CSTB-5 | T-20D | \$584.84 |
| TDSU1812-03 | ● | 1.812 | | | 5.436 | | 10.174 | .015 | 4.6 | | | | \$584.84 |
| TDSU1875-03 | ● | 1.875 | | | 5.625 | | 10.424 | .094 | 4.9 | | | | \$678.18 |
| TDSU1937-03 | ● | 1.937 | | | 5.811 | | 10.674 | .078 | 5.1 | | | | \$678.18 |
| TDSU2000-03 | ● | 2.000 | | | 6.000 | | 10.924 | .067 | 5.5 | | | | \$678.18 |

Inserts

DS Chipbreaker

NEW

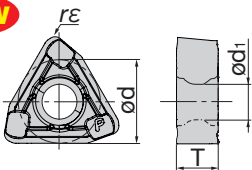

DJ Chipbreaker

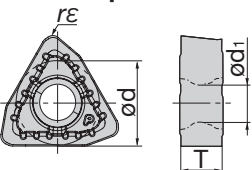

| Cat. No. | Stocked grades | Dimensions (in) | | | | Applicable drill diameters |
|-----------------------|----------------|-----------------|------|-----------------|----------------|----------------------------|
| | | ød | T | ød ₁ | r _ε | |
| WWWU08X408R-DS AH6030 | ● | .315 | .154 | .134 | .031 | ø1.125 ~ ø1.250 |
| WWWU08X408R-DJ AH9030 | ● | .315 | .154 | .134 | .031 | ø1.125 ~ ø1.250 |
| WWWU09X510R-DS AH6030 | ● | .382 | .193 | .173 | .039 | ø1.312 ~ ø1.500 |
| WWWU09X510R-DJ AH9030 | ● | .382 | .193 | .173 | .039 | ø1.312 ~ ø1.500 |
| WWWU11X512R-DS AH6030 | ● | .445 | .224 | .217 | .047 | ø1.562 ~ ø1.812 |
| WWWU11X512R-DJ AH9030 | ● | .445 | .224 | .217 | .047 | ø1.562 ~ ø1.812 |
| WWWU13X512R-DS AH6030 | ● | .512 | .224 | .217 | .047 | ø1.875 ~ ø2.000 |
| WWWU13X512R-DJ AH9030 | ● | .512 | .224 | .217 | .047 | ø1.875 ~ ø2.000 |



Promo code: TG026 • Offers valid until December 31st, 2013



Tungaloy America, Inc.

3726 N Ventura Drive, Arlington Heights, IL 60004, U.S.A.
Inside Sales: +1-888-554-8394
Technical Support: +1-888-554-8391
Fax: +1-888-554-8392

www.tungaloyamerica.com



Become a fan on facebook



Follow us on Twitter @tungaloy



Watch our videos on You Tube

Promo Details for Authorized Tungaloy Distributors

- Orders must be drop shipped
- Promotional pricing not applicable when ordering online
- Promo code must be used when ordering
- Prices valid in U.S. only
- Standard terms and conditions apply

Distributed by:



Scan for instant
web access